

Steamfitter/Pipefitter

Practice Interprovincial Red Seal Exam

Disclaimer: This is NOT an Interprovincial Standards (Red Seal) Examination. This is a practice examination that has been developed using similar weighting, question distribution, question taxonomies and question styles to that of a red seal examination. Success on this examination will NOT result in certification or qualification. This examination is intended to be used for self assessment in preparation for attempting a red seal examination. More information about the standard that the red seal examination is based on may be found within the National Occupational Analysis for the occupation at www.red-seal.ca .

Section 1

OCCUPATIONAL SKILLS

1. What is the correct size of socket required to remove a 2H nut on a 1¼" stud bolt?
 - A. 1½"
 - B. 1⅞"
 - C. 2"
 - D. 2¹/₁₆"

2. What affects the speed of a pneumatic grinder?
 - A. Air pressure.
 - B. Air flow.
 - C. Torque rating.
 - D. Air quality.

3. On a single line pipe drawing what two methods of measurement would be found?
- A. End to end and face to centre.
 - B. End to end and face to end.
 - C. Centre to centre and face to centre.
 - D. End to end and centre to end.
4. What does the term SMAW represent?
- A. Standard Metal Arc Welding.
 - B. Shielded Metal Arc Welding.
 - C. Submerged Metal Arc Welding.
 - D. Standard Metal Air Welding.
5. What is the primary purpose of soldering flux?
- A. Promote capillary action.
 - B. Remove impurities.
 - C. Provide a good finish.
 - D. Prevent oxidation.
6. What is the minimum distance a portable ladder is to extend above a work platform?

	<u>Imperial</u>		<u>Metric</u>
A.	300 mm	A.	12"
B.	600 mm	B.	24"
C.	1000 mm	C.	36"
D.	1200 mm	D.	48"





7. When would WHMIS require the use of a workplace label?
- A. When the MSDS is missing from a controlled product.
 - B. When a controlled product is transferred from its' original container.
 - C. When a controlled product is shipped from the manufacturer.
 - D. When the instructions for use are missing.
8. Where must a safety harness lanyard be attached?
- A. To a fixed anchor capable of bearing the shock load which may be applied.
 - B. To a fixed anchor capable of bearing the static load which may be applied.
 - C. To any overhead support that allows sufficient movement.
 - D. To any fixed anchor providing a shock absorbing lanyard is utilized.
9. A site issued change notice requires the fabrication of fifteen (15), 4" (100 mm) welded spools. Each spool consists of eight (8) welds. With a charge out rate of \$12.00 per welded inch, what is the cost of the project?
- A. \$384.00
 - B. \$1507.00
 - C. \$5760.00
 - D. \$18064.00
10. What is considered a confined space?
- A. An area with limited headroom.
 - B. An area with limited access and egress.
 - C. An area where welding operations take place.
 - D. An area with inadequate ventilation.

11. A 12" (300 mm) carbon steel pipe is carrying naphtha from a distillation column to a storage tank. What code governs the construction and testing of this line?
- A. CSA Z662
 - B. ANSI/ASME Section VIII
 - C. ANSI/ASME B 31.1
 - D. ANSI/ASME B 31.3

12. At what pipe size does standard weight pipe maintain a constant wall thickness?

	<u>Imperial</u>		<u>Metric</u>
A.	8"	A.	200 mm
B.	10"	B.	250 mm
C.	12"	C.	300 mm
D.	14"	D.	350 mm

13. Which blueprint symbol represents a threaded 90 degree elbow?

- A) 
- B) 
- C) 
- D) 

14. What must be completed prior to a hydrostatic test on a registered system?
- A. Ensure all material is traceable and welder ID's are recorded.
 - B. Ensure all pressure relieving devices have been installed.
 - C. Ensure all shipping constraints have been removed from constant support hangers.
 - D. Ensure all pipe insulation and coverings are in place.

Section 2

DRAWINGS AND SPECIFICATIONS

15. If the piping system you install deviates from the engineered drawings, what procedure should be followed?
- A. Make a mental note of all the changes and be prepared to present them at the weekly sight meeting.
 - B. Write down all the changes and store them in a safe place for future reference.
 - C. Write down all the changes and send it to your company supervisor.
 - D. Document all as-built alterations and submit them to the engineer.
16. The plug valves listed in the specifications give you a specific model or equivalent and on the drawings only show the specific model. What does this mean?
- A. Use the specific model plug valve only.
 - B. Use the specific model plug valve or an equivalent model.
 - C. Use the equivalent model plug valve only.
 - D. There is a conflict between the specifications and the prints.
17. On the legend, a triangle with the number 3 has “Revised, See Revision List”. On your set of blue prints the same triangle with a number 3 in it points to a “cloud like” circle surrounding a valve on a control station. If there are twelve control stations what does this mean?
- A. Changes will take place on all twelve stations.
 - B. There will need to be approval from the site engineer before these changes will take place.
 - C. On reading the revision list, only those stations noted will be changed.
 - D. On reading the revision list, only those stations noted will be changed after the project is complete.

18. Which of the following best describes an established elevation above sea level?
- A. Floor elevation.
 - B. Geodetic elevation.
 - C. Bench mark.
 - D. Base line location.
19. Referring to Figure 2, What does the symbol represent?
- A. Flange going away.
 - B. Tee going away.
 - C. Tee coming toward you.
 - D. Top of a valve.
20. In comparing 1:20 to 1:200 drawing ratio on a scale rule, which statement is correct?
- A. The 1:20 drawing scale will cover the same as the 1:200 drawing scale.
 - B. The 1:20 drawing scale will cover 10 times more area than the 1:200 drawing scale
 - C. The 1:200 drawing scale will cover 10 times more area than the 1:20 drawing scale
 - D. The 1:200 drawing scale will cover 20 times more area than the 1:20 drawing scale.
21. On your survey sheet you have written the bench mark at 213.189m (699'5"), the back sight to be .514m (1'8") and the foresight to be 697mm (2' 4 $\frac{7}{8}$ "). Calculate the Height of instrument (HI).

	<u>Metric</u>	<u>Imperial</u>
A.	213.189 m	A. 699'5"
B.	212.675 m	B. 697'9"
C.	213.886 m	C. 701'9"
D.	213.703 m	D. 701'1"

22. On a set of drawings each **Temperature Recorder Controller** is followed by a dash and a number. What does the number tell you?
- A. Different kinds of Temperature Recorder Controllers on the plant site.
 - B. Loop Number of the Temperature Recorder Controllers on the plant site.
 - C. The way a supplier keeps track of the number of Temperature Recorder Controllers sent out.
 - D. The number of Temperature Recorder Controllers on the plant site.
23. On a P & I D drawing you have located the vessel where you are to install a spool. In order to place it in the correct location, what information from the mechanical prints would you need?
- A. Grid co-ordinates and elevations from the mechanical plans.
 - B. Grid co-ordinates and elevations found on the P & ID drawing.
 - C. Grid co-ordinates and elevations from the detail drawings.
 - D. Grid co-ordinates from the mechanical plans and elevations from the detail drawings.
24. When looking at an elevation view, why is it critical to know which view it is with reference to the north arrow?
- A. In the event the north arrow needs to be rotated to allow a less cluttered view in isometric.
 - B. To ensure the elevations for both the equipment and piping are correct.
 - C. There are no north arrows on any elevation views.
 - D. To ensure the locating and positioning of all equipment and piping is correctly orientated.

25. Which of the cutting plane lines in Figure 1 provides the view of V-111 needed in elevation?

- A. Cutting plane CC.
- B. Cutting plane AA.
- C. Cutting plane BB.
- D. Cutting plane AB.

26. A standard steel 14 inch (350mm) steam line must pass through a concrete foundation wall. What size of core is required to maintain a 1 inch (25mm) clearance around the pipe?

- | | <u>Imperial</u> | | <u>Metric</u> |
|----|-----------------|----|---------------|
| A. | 16 inch | A. | 400mm |
| B. | 15 inch | B. | 375mm |
| C. | 17 inch | C. | 350mm |
| D. | 18 inch | D. | 450mm |

27. The specifications indicate a sleeve to be installed in a concrete wall to accommodate a 12" (300mm) pipe. The pipe will have 1" (25 mm) of continuous hot insulation through the sleeve. If you are using schedule 40 pipe for the sleeve, what size is required to be added to your materials list?

- | | <u>Imperial</u> | | <u>Metric</u> |
|----|-----------------|----|---------------|
| A. | 14" | A. | 350mm |
| B. | 16" | B. | 400mm |
| C. | 18" | C. | 450mm |
| D. | 20" | D. | 500mm |

28. Identify what way you can distinguish between equal spread and unequal offsets?
- A. Unequal spread offsets narrow centre to centre through the travel.
 - B. Unequal spread offsets narrow centre to centre on either side of the travel.
 - C. Unequal spread offsets narrow centre to centre on piping before the travel.
 - D. Unequal spread offsets narrow centre to centre on piping after the travel.
29. Refer to Figure 7. The piece for a true Y has been cut off centre due to an error on your template. What would be the result when all three pieces are tacked?
- A. No problem if the cut angles are correct.
 - B. Excessive misalignment and high/low.
 - C. Incorrect angle of the pieces.
 - D. Incorrect gap between the pieces.
30. After dividing a pipe into 16 parts, the last ordinate space is short of the starting point by $\frac{1}{4}$ inch (6mm). How can this be corrected?
- A. Divide a sheet of paper the length of the pipe circumference, into 16 equal parts.
 - B. The tape moved causing misalignment. Repeat procedure.
 - C. In the ordinates book use the information under "extra strong pipe".
 - D. Recalculate the circumference of the pipe.
31. What is the formula to calculate the cut back on a length of pipe to make a three-piece 90 elbow?
- A. I.D. of the pipe multiplied by the cut angle factor all divided by 2.
 - B. O.D. of the pipe multiplied by 2 all divided by the cut angle factor.
 - C. O.D. of the pipe multiplied by the cut angle factor all divided by 2.
 - D. Nominal pipe size multiplied by the cut angle factor all divided by 2.

32. Refer to Figure 3. Which application is the template used for?
- A. Equal Tee.
 - B. 45 Degree Lateral.
 - C. Mitre Turn.
 - D. Orange Peel.

Section 3

PIPING LAYOUT AND COMMON INSTALLATION

33. When fabricating a template for a reducing branch on a header, what information is required?
- A. The weld procedure.
 - B. The pipe is A53 ERW Type F.
 - C. The pipe is A 106 Grade A Seamless.
 - D. The branch is saddle in or saddle on.
34. When looking at a typical ASTM pipe marking, what process of manufacture does the letter S indicate?
- A. Spiral welded.
 - B. Seamless.
 - C. Steam working pressure.
 - D. Stamped.
35. On a 1" X 1" X 2" black malleable tee, what does the 2" refer to?
- A. Larger run opening.
 - B. Branch opening.
 - C. Eccentric tee configuration.
 - D. Concentric tee configuration.
36. Calculate the face to centre dimension of a 6" (150 mm) schedule 40 butt weld LR 90° elbow.

Imperial

Metric

- | | |
|------------------------------------|-----------|
| A. 3 ³ / ₄ " | A. 95 mm |
| B. 6" | B. 150 mm |
| C. 9" | C. 225 mm |
| D. 12" | D. 300 mm |

37. Calculate the fitting allowance for a threaded black malleable 90° elbow with a throw of 2" (50 mm), and a thread engagement of $\frac{5}{8}$ " (16mm).

Imperial

Metric

- | | | | |
|----|-------------------|----|-------|
| A. | 1 $\frac{3}{8}$ " | A. | 36 mm |
| B. | 2" | B. | 50 mm |
| C. | 2 $\frac{5}{8}$ " | C. | 67mm |
| D. | 3" | D. | 75 mm |
38. When marking a circumference line, what is the minimum length of wrap-around required?
- A. 1 $\frac{1}{4}$ times the circumference of the pipe.
 - B. 1 $\frac{3}{4}$ times the circumference of the pipe.
 - C. 2 times the circumference of the pipe.
 - D. 2 $\frac{1}{2}$ times the circumference of the pipe.
39. Refer to Figure 6. What must be done to correct the fit-up in the drawing below?
- A. More grinding required at "2".
 - B. More grinding required at "1".
 - C. More grinding required at "3".
 - D. More grinding required at "1" and "3".
40. What should be done with a drill press as the size of a drill bit increases?
- A. Keep speed constant for all sizes of drill bits.
 - B. Decrease speed as the size of the drill bit increases.
 - C. Increase speed as the size of the drill bit increases.
 - D. Use more oil as the size of the drill bit increases.
41. When welding 316L stainless steel with a GTAW root and a SMAW fill and cap, what is the recommended procedure to ensure a clean finish?
- A. Preheating.
 - B. Stress relieving.
 - C. Pickling.
 - D. Passivating.

42. When butt welding a 12" (300 mm) schedule 40 bore RFWN flange (ID 11.938"/303 mm) to a 12" schedule 80 pipe (ID 11.374"/289 mm), how long will the transition be when grinding the inside of the pipe to remove the high low?

Imperial

Metric

- | | | | |
|----|--------|----|-------|
| A. | 0.282" | A. | 7 mm |
| B. | 0.564" | B. | 14 mm |
| C. | 1.128" | C. | 28 mm |
| D. | 2.256" | D. | 56 mm |
43. What is the suggested procedure for butt welding concrete lined steel pipe?
- A. Use a consumable metallic backing ring.
 - B. Use a non-consumable metallic backing ring.
 - C. Use a heat resistant gasket spot glued to the liner.
 - D. Use a type "D" RTJ gasket spot glued to the liner.
44. When joining copper tube to copper tube in a refrigeration system, what would you use?
- A. 95% tin and 5% antimony solder with flux.
 - B. BAg-5 silver solder with flux.
 - C. BAg-5D silver solder without flux.
 - D. BCuP-5 without flux.
45. Where vertical movement due to thermal expansion or contraction is greater than ½", which of the following supports should be used?
- A. Riser clamp.
 - B. Cantilever bracket.
 - C. Steel clevis hanger.
 - D. Constant support hanger.

46. Which type of pipe would be most susceptible to point loading damage?
- A. PVC with high temperature product in the line.
 - B. PVC with low temperature product in the line.
 - C. Steel pipe with high temperature product in the line.
 - D. Steel pipe with low temperature product in the line.
47. Which code, standard or reference is used for hanger spacing when installing steel pipe containing natural gas in a service building within a refinery?
- A. CSA Z662.1 Oil and Gas pipeline systems.
 - B. ASME/ ANSI B31 Process piping code.
 - C. B149.1 Natural gas and Propane Installation Code.
 - D. Canadian Building Safety Standards Reference.
48. A continuous blow down line is 84' (25.2 m) long grading down at 1.041%. The hangers are spaced 10' (3 m) apart, and the first hanger is 2' (.6 m) from the start of the line. If the first hanger is 18 $\frac{1}{4}$ " (.465 m) long, what is the length of the 7th hanger?

Imperial

Metric

- | | | | |
|----|--------------------|----|--------|
| A. | 24 $\frac{3}{4}$ " | A. | 620 mm |
| B. | 25 $\frac{3}{4}$ " | B. | 654 mm |
| C. | 26 $\frac{3}{4}$ " | C. | 670 mm |
| D. | 27 $\frac{3}{4}$ " | D. | 694 mm |
49. When purging a stainless steel line for welding, where should Argon gas be introduced?
- A. At the low point.
 - B. At the high point.
 - C. Inside the pipe at the joint.
 - D. Outside the pipe at the joint.

50. When soldering a copper pipe to a copper fitting using 95/5 solder with a petroleum base flux, what would be the result if the joint is heated to a red color?
- A. The solder would flow into the joint by capillary attraction and make a leak proof seal.
 - B. The joint will not be satisfactory unless purged with Nitrogen.
 - C. The joint will not be hot enough and the solder will not turn liquidus.
 - D. The joint will be too hot and the flux will burn.

51. What is the best way to make a threaded transition from PVC to brass?
- A. Thread a brass male thread into a female PVC thread.
 - B. Thread a PVC male thread into a brass female thread.
 - C. Use a dielectric union.
 - D. Use a transition union.

52. What is the recommended gap for a socket weld fitting?

<u>Imperial</u>	<u>Metric</u>
A. $\frac{5}{32}$ "	A. 4 mm
B. $\frac{1}{8}$ "	B. 3 mm
C. $\frac{3}{32}$ "	C. 2 mm
D. $\frac{1}{16}$ "	D. 1 mm

53. When a combination make up water feeder and low water cutoff is installed on an automatically fired steam boiler, which other control is required?
- A. A flow switch.
 - B. A low water alarm.
 - C. A second low water cut off.
 - D. A 24 hour operator monitoring water level and pressure.

54. When is a Reduced Pressure Principle Backflow Preventer required?
- A. When the boiler feed water supply is rainwater.
 - B. When the boiler feed water is from lakes or rivers.
 - C. When the boiler feed water is thermally treated.
 - D. When the boiler feed water is from a potable source.
55. To isolate a system with a double block and bleed valve, how should the bleed valve be set?
- A. Fully closed.
 - B. 50% open.
 - C. 75% open.
 - D. Fully open.
56. What device is installed on the downstream side of a high pressure steam safety valve that vents to the roof?
- A. Exhaust head.
 - B. Drip pan elbow.
 - C. Double block and bleed.
 - D. Safety valve de-accumulator.
57. On a high pressure steam boiler with a safety valve set at 30psi, what is the recommended range for the pressure gauge?

Imperial

Metric

- | | |
|--------------------|-------------------------|
| A. 0 to 30 psi | A. 0 to 210 kPa |
| B. 0 to 60 psi | B. 0 to 420 kPa |
| C. 30”Hg to 30 psi | C. 760 mm Hg to 210 kPa |
| D. 30”Hg to 60 psi | D. 760 mm Hg to 420 kPa |

58. A low pressure cast iron sectional boiler has a safety valve set at 15 psi. What test pressure is required?
- A. 15 psi
 - B. 22.5 psi
 - C. 30 psi
 - D. 45 psi

SECTION 4

RIGGING AND HOISTING

59. Using the rule of thumb for steel plate, what is the approximate weight of a piece of 24", 0.375 wall pipe that is 10 feet long? (1' x 1' x 1" steel = 40 lbs.)
- A. 300 lb
 - B. 942 lb
 - C. 2512 lb
 - D. 11304 lb
60. Using the rule of thumb for wire rope, what is the safe working load for a 1" diameter IWRC 6X19 wire rope?
- A. 1500 lb
 - B. 2000 lb
 - C. 12,000 lb
 - D. 16,000 lb
61. A block has four parts of line and uses roller bearing sheaves that cause 3% friction. If the load weighs 4000 lb, how much pull must be placed on the lead pull line to hold the load once it has been lifted?
- A. 1000 lb
 - B. 1030 lb
 - C. 1126 lb
 - D. 4000 lb
62. Refer to Figure 5. If B is located above the center of gravity of the lift, AB is 10' long, and BD is 2' long, what length is distance BC?
- A. 2'
 - B. 3'
 - C. 4'
 - D. 8.6'

63. Which of the following would be most suitable to join two dissimilar sized fibre ropes together?
- A. Clove hitch.
 - B. Square knot.
 - C. Carrick bend.
 - D. Bowline.
64. Which type of block is designed to change the angle of pull for a wire rope?
- A. A snatch block.
 - B. A set of wire rope blocks.
 - C. A crane block.
 - D. A set of tackle blocks.
65. Refer to Figure 4. The load radius is 23' and the boom length is 64', what is the maximum allowable load?
- A. 31,900 lb
 - B. 34,300 lb
 - C. 36,300 lb
 - D. 37,900 lb
66. An L- shaped pipe spool is 6' long and 4' high. The weights of the two pieces of pipe and $\frac{1}{2}$ of the elbow are equivalent to their lengths. Along a line drawn between the centers of gravity of both pieces, how far is the new center of gravity from the center of the shorter piece?
- A. 2.9'
 - B. 4'
 - C. 4.3'
 - D. 6'

67. A double-wrap choker hitch must be used on a 24" pipe. The measurement from the top of the pipe to center of the hook is 7.44'. How long is the sling?
- A. 12'
 - B. 16'
 - C. 18'
 - D. 20'
68. What is the purpose of using an open palm in conjunction with a hand signal?
- A. Move load quickly.
 - B. Move load slowly.
 - C. Emergency stop.
 - D. Swing load left.
69. When installing a turnbuckle that will be subject to vibration, how is the turnbuckle secured?
- A. Jam Nut.
 - B. Peen threads.
 - C. Lock wire.
 - D. Mouse hook.
70. If the slings must be placed at a 30 degree angle in order to perform a 2500 lb lift, what weight must each sling be able to bear?
- A. 1250 lb
 - B. 1767.5 lb
 - C. 2500 lb
 - D. 5000 lb
71. If you are using a lattice boom crane, and the load needs to be lifted both outward and upward, what signals must you use to place the lift?
- A. Raise the boom and hold the load.
 - B. Lower the boom and hold the load.
 - C. Raise the load and then lower the boom and hold the load.
 - D. Lower the boom and hold the load and then raise the load.

SECTION 5

STEAM SYSTEM INSTALLATION

72. What would happen to a soot blower inserted into the combustion gas stream of a high pressure boiler when no steam is flowing into the soot blower?
- A. The wand will bend.
 - B. The fuel nozzle will melt.
 - C. The nozzle will plug.
 - D. The view window will distort.
73. What is used to return the condensate to a steam boiler when the system operates at 5" hg. to 2 psig?
- A. Pump and receiver.
 - B. Boiler return trap.
 - C. Vacuum pump and receiver.
 - D. Deaerator and pump.
74. What is the recommended turn down ratio from the high pressure side to the low pressure side of a pressure reducing valve?
- A. 1 to 1
 - B. 5 to 1
 - C. 10 to 1
 - D. 20 to 1
75. What procedure should be followed to eliminate vibration created from a base mounted pump?
- A. Anchor the pump to the house keeping pad.
 - B. Support the pump independently from the piping.
 - C. Install the pump on an inertia base and spring isolators.
 - D. Install acoustic insulation around the pump motor.

76. Which piece of equipment is the exhaust steam from the high pressure turbine piped to?
- A. Pendant super-heater.
 - B. Convection super-heater.
 - C. Convection re-heater.
 - D. Pendant re-heater.
77. An installation requires 225' of 24" high pressure carbon steel steam line at 75° F with an intended operating temperature of 325° F. How much cold spring is required per leg of an expansion loop?
- A. $\frac{9}{16}$ "
 - B. $1\frac{1}{8}$ "
 - C. $2\frac{1}{4}$ "
 - D. $4\frac{1}{2}$ "
78. What would be required if a sleeve-type expansion joint is received fully compressed?
- A. Install the expansion joint as is, and wait until the line is at its maximum operating temperature before installing the anchors.
 - B. Install a piping offset in place of the expansion joint.
 - C. Install the expansion joint in a location that is easily accessed for service.
 - D. Install the expansion joint, after pulling the joint open mechanically to the amount required.
79. How can heat transfer between the tracing and the product line be improved?
- A. Increase the size of the tracing lines.
 - B. Double the amount of insulation surrounding the tracing and the product line.
 - C. Increase the steam pressure to the system.
 - D. Use heat-conducting paste.

80. When using a tube/tubing bender to make a left hand 90° bend, where is the measured mark placed?
- A. Aligned with the "90" on the bending wheel.
 - B. Aligned with the "90" on the placement link.
 - C. Aligned with the "0" on the placement link.
 - D. Aligned with the "0" on the bending wheel.

81. A low-pressure steam boiler has four 2" (50 mm) steam nozzles, what is the minimum size of the steam header?

Imperial

Metric

- | | | | |
|----|----|----|--------|
| A. | 2" | A. | 50 mm |
| B. | 3" | B. | 75 mm |
| C. | 4" | C. | 100 mm |
| D. | 6" | D. | 150 mm |
82. When installing a threaded piping system up to NPS DN20 ($\frac{3}{4}$ ") for connection to gas fired equipment, what is the minimum schedule of steel pipe allowed for nipples?
- A. Sch 10.
 - B. Sch 40.
 - C. Sch 80.
 - D. Sch 160.
83. When installing two (2) pressure reducing valves (PRVs) in series, what is the recommended spacing between the valves?

Imperial

Metric

- | | | | |
|----|---------|----|-------|
| A. | 2 feet | A. | 0.6 m |
| B. | 5 feet | B. | 1.5 m |
| C. | 8 feet | C. | 2.4 m |
| D. | 10 feet | D. | 3.0 m |

84. What is the first action taken when the boiler is firing and no water is visible in the sight glass?
- A. Shut off the steam supply to the system.
 - B. Prove that the sight glass is operational.
 - C. Reset the low water cut-off switch.
 - D. Shut off the fuel supply to the boiler.
85. When installing 25 feet of two tier fin vector baseboard with a rating of 6.7 EDR/foot, how much heat is available?
- A. 47 250 Btu
 - B. 40 200 Btu
 - C. 29 400 Btu
 - D. 28 800 Btu
86. When installing a 400 mm (16") carbon steel high pressure steam main, what is the diameter of the drip leg required at the end of the main?
- | <u>Metric</u> | <u>Imperial</u> |
|---------------|-----------------|
| A. 50 mm | A. 2" |
| B. 100 mm | B. 4" |
| C. 200 mm | C. 8" |
| D. 400 mm | D. 16" |
87. What should be done with the isolation valves on a high pressure steam system before breaking open the pipe joints for repair?
- A. Open the valves fully to equalize the pressure with the system.
 - B. Remove the valve handles so the valves can't be operated.
 - C. Determine the pressure in the mains ahead of the isolation valves.
 - D. Check that the valves are closed, tagged and locked out.

88. How should eccentric reducers be installed in lines used for condensable vapours?
- A. Flat on the bottom for horizontal lines.
 - B. Flat on the top for horizontal lines.
 - C. With the centre lines of the inlet and outlet at the same elevation.
 - D. Flat on the bottom in vertical lines.
89. What piece of equipment is required on a large water tube boiler with inadequate gravity circulation?
- A. Base-mounted pump.
 - B. Inline down-comer circulator.
 - C. Deaerator storage drum.
 - D. Vacuum/condensate pump.

SECTION 6

HEATING, COOLING AND PROCESS SYSTEM INSTALLATION

90. Prior to selecting a hydronic circulator what must be determined?
- A. Height of building and pipe size.
 - B. Height of building and flow rate.
 - C. System resistance and pipe size.
 - D. System resistance and flow rate.
91. On a hydronic heating system what is the purpose of a line scoop?
- A. Separates gases from the heating medium.
 - B. Removes gases from the heating medium.
 - C. Controls the expansion of the heating medium.
 - D. Controls the flow of the heating medium.
92. A building loses 125,000 Btu/hr, what is the gross rating of a boiler with 25% heat loss through the system piping?
- A. 93,750 Btu/hr
 - B. 125,000 Btu/hr
 - C. 156,250 Btu/hr
 - D. 166,667 Btu/hr
93. A chiller for a skating rink is rated at 50 Tons. How many Btu/hr is this unit capable of removing?
- A. 48,500 Btu/hr
 - B. 350,000 Btu/hr
 - C. 500,000 Btu/hr
 - D. 600,000 Btu/hr

94. In a vestibule with limited wall space and high heat loss what heat transfer unit would be most suitable?
- A. Unit heater.
 - B. Convector.
 - C. Baseboard radiation.
 - D. Blast coil.
95. When sizing an air cushion tank for 50% glycol, how much larger than a water system would it have to be?
- A. 20%
 - B. 30%
 - C. 35%
 - D. 50%
96. When using High Temperature Hot Water generators, where is lower temperature water returned in the system?
- A. No return, water must be 100% make up.
 - B. To the expansion drum.
 - C. To the suction side of the circulator.
 - D. To the inlet of the generator.
97. Which of the following tools is used to check the performance of a base mounted hydronic pump?
- A. Millivolt meter.
 - B. Ammeter.
 - C. Voltmeter.
 - D. Ohmmeter.
98. Where in a refrigeration system does the refrigerant absorb heat?
- A. Compressor.
 - B. Condenser.
 - C. Expansion valve.
 - D. Evaporator.

99. Where is the preferred location of an orifice plate in a piping system?
- A. 5 diameters of straight pipe downstream of a PRV.
 - B. 8 diameters of straight pipe upstream of a PRV.
 - C. 10 diameters of straight pipe downstream of a PRV.
 - D. 2½ diameters of straight pipe upstream of a PRV.
100. A heat exchanger is to be installed 6' (1800 mm) from a wall and it requires a minimum of 80" (2 m) to remove the bundle. What procedure should be followed?
- A. Have the wall moved 8" (200 mm).
 - B. Provide a knock out in the wall.
 - C. Move the exchanger 8" (200 mm).
 - D. Turn the exchanger 180 degrees.
101. What is used to align a flexible coupling on a base mounted pump?
- A. Combination square and level.
 - B. Straight edge and feeler gauge.
 - C. Water level and straight edge.
 - D. Vernier calliper and micrometer.
102. According to ASME Section I, which type of material is not allowed inside a boiler?
- A. Brass.
 - B. Carbon steel.
 - C. Stainless steel.
 - D. Galvanized steel.
103. What does the designation "L" represent in 316L stainless steel pipe?
- A. Low carbon content.
 - B. Low iron content.
 - C. Low chrome content.
 - D. Low nickel content.

104. Which type of valve would be used on a pipe line that carries boiler ash in slurry?
- A. Solid wedge gate valve.
 - B. Knife gate valve.
 - C. Plug disc globe valve.
 - D. Composition disc globe valve.
105. Why does a 2" (50 mm) chrome-moly butt weld joint need to be stress relieved?
- A. To reduce intragranular carbide precipitation.
 - B. To soften the HAZ.
 - C. To increase the strength of the weld.
 - D. To reduce the chance of cracking.
106. When joining fibreglass reinforced plastic (FRP) pipe, what must be done to ensure adhesion of the resin to the existing pipe?
- A. Clean pipe with acetone.
 - B. Clean pipe with water.
 - C. Remove wax layer.
 - D. Remove fibre layer.
107. On a hydraulic line, what is the correct type of ring type joint RTJ gasket to be installed?
- A. Crush Ring.
 - B. Spiral wound.
 - C. Type D.
 - D. Type A.
108. When cut grooving steel pipe for a hydraulic system what is the minimum wall thickness of pipe required?
- A. Schedule 10.
 - B. Schedule 40.
 - C. Schedule 80.
 - D. Schedule 160.

109. Prior to initial start-up of a diesel generator, what is required?
- A. Purge air from the system.
 - B. Engage starter to start fuel flow.
 - C. Ensure day tank is located above generator.
 - D. Purge fuel from the system.
110. What device activates the motor in an instrument air compressor?
- A. Level switch.
 - B. Temperature switch.
 - C. Vacuum switch.
 - D. Pressure switch.
111. When installing utility air piping with filter regulating lubricating (FRL) stations, where are dirt pockets installed?
- A. On drops after the stations.
 - B. On drops before the stations.
 - C. On risers after the stations.
 - D. On risers before the stations.

SECTION 7

TESTING AND COMMISSIONING

112. During the completion of a punch list, the engineer has sent out a revision on torque values for all flanges on the pipeline. All torque values are lower than originally specified. What is the correct procedure to remedy this issue?
- A. Loosen flanges and re-torque to specified value.
 - B. Leave flanges torqued at the higher value.
 - C. Replace gaskets and re-torque to specified value.
 - D. Send the engineer an RFI for clarification.
113. Which type of pump should be used for hydrostatic testing?
- A. Centrifugal flow pump.
 - B. Radial flow pump.
 - C. Axial flow pump.
 - D. Positive displacement pump.
114. Hydrostatic testing is to be performed on a blinded 24" 300 lb. flange. The test pressure is 1080 psig. What is the approximate force produced on the blind?
- A. 40,695 lbs force.
 - B. 81,389 lbs force.
 - C. 155,520 lbs force.
 - D. 488,330 lbs force.
115. When filling a pipeline for hydrostatic testing, how should the vent and drain valves be positioned?
- A. Vents open and drains closed.
 - B. Vents open and drains open.
 - C. Vents closed and drains open.
 - D. Vents closed and drains closed.

116. The CSA Z7396-1 (medical gas piping code) requires all piping to be tested at 150 psig (1050 kPa) for 24 hours with nitrogen. The code allows 1 psig (7 kPa) variation for every 2 degrees Fahrenheit temperature change. If the test starts at 12:00 PM at a temperature of 60 degrees F, what will the test pressure be at 5:00 PM when the temperature is 84 degrees F?

Imperial

Metric

- | | | | |
|----|----------|----|----------|
| A. | 138 psig | A. | 966 Kpa |
| B. | 150 psig | B. | 1050 Kpa |
| C. | 162 psig | C. | 1134 Kpa |
| D. | 174 psig | D. | 1218 Kpa |
117. A boiler feed water pump has a leaking packing, what adjustment can a Steamfitter do?
- A. Stop the pump and tightening the packing gland with a pipe wrench.
 - B. Apply a water tight silicone to the packing.
 - C. Loosen the packing and install more packing material.
 - D. Carefully tighten the packing while the pump is running.
118. When testing piping and a hydrostatic test is not practical, can a pneumatic test be performed?
- A. Because of the hazards involved a pneumatic test will not be permitted.
 - B. Approval of the Safety Codes Officer is required.
 - C. Approval of the Safety Codes Officer and acceptance from the owner.
 - D. Approval of the Safety Codes Officer and site superintendant.
119. When testing for Total Dissolved Solids in a power boiler, where is the test water drawn?
- A. The lowest part of the boiler.
 - B. The intermittent blow-off.
 - C. The chemical pot feeder.
 - D. The continuous blow-down.

120. Prior to commissioning a lube oil system, what procedure must be done?
- A. The system must be tested, flushed and pickled.
 - B. The test medium must be removed and the system filled with oil.
 - C. A combination of oil and water must be circulated through the system.
 - D. The system must be pneumatically tested to its yield point.

SECTION 8

MAINTENANCE AND REPAIR

121. What is the procedure for starting a locked out piece of equipment when the lock out key is not available?
- A. The supervisor will phone engineering to remove the lock by whatever means and continue the start up procedure.
 - B. The supervisor will phone his supervisor to remove the lock by whatever means and continue the start up procedure.
 - C. The supervisor will follow site and company lock out protocol, remove the lock by whatever means and continue the start up procedure.
 - D. The supervisor will call the operating engineer to remove the lock and then continue the start up procedure.
122. Gaskets in a flanged valve require replacement. The maintenance procedure requires a force of 125 lb to a torque wrench at a distance of 2' 9" feet from the centre of the stud. What is the torque applied?
- A. 125 ft-lb.
 - B. 345 ft-lb.
 - C. 125 lb force.
 - D. 345 lb force.
123. While inspecting a hydraulic system it is noted that formation of sludge, gums, carbon or other deposits are clogging openings, causing valves and pistons to stick or leak and giving poor lubrication to moving parts. What condition in the hydraulic system causes these detrimental occurrences?
- A. Excess water.
 - B. Contact with oxygen absorbed in the receiver tank.
 - C. Bacterial contamination.
 - D. Exposure to excessive heat and pressure.

124. During a shutdown material is received that does not have material test reports (MTR's). What should be done with the material?
- A. Use the material in the lowest pressure system.
 - B. Use the material and request an approval from the mechanical engineer.
 - C. Use the material with the general contractor's approval.
 - D. Consult with the project manager (PM) and return the material to the supplier.
125. A crew is required to de-commission a very large LPG fuel piping system. The system runs off of a manifold, supplying a large number of pieces of equipment. What must be done before leaving the occupied work area?
- A. Shut off and securely store the cylinders and equipment.
 - B. Shut off the cylinders and remove the regulator pressure screw.
 - C. Shut off and tag the valves.
 - D. Remove both the cylinders and equipment from the occupied space.
126. A valve has failed on the supply header of an existing steam tracing system. Prior to the valve failure, the system worked well. The tracing is tied into an existing valve on the header that was intended for future use. After following proper start-up procedures, it is discovered that the tracing fills with condensate. To solve the problem, what is the first thing that should be done?
- A. Check for blockages in the thermodynamic trap on the return header.
 - B. Check with the engineer to see if tying into the new valve overloaded the system.
 - C. Check to see if tracing is kinked.
 - D. Check to see if the existing valve needs to be rodded for calcification.

127. A sump pump in a refinery has become very loud and it is clear that it will need to be removed and replaced. The pump is located at the bottom of the sump, which is 1 metre (39.4") deep. If the correct pump and materials are available, what special hazards must be accounted for, before replacing the pump?
- A. No special hazard precautions are required.
 - B. A lock out is required.
 - C. A lockout and a confined space entry permit are required.
 - D. A lock out, a confined space entry permit, and a hot permit are required.
128. Due to a change in the process, an existing expansion loop will now be subject to a temperature differential 100 degrees Celcius (212 degrees Fahrenheit) less than it was originally designed to handle. What should be done to the expansion loop to account for this change?
- A. The flex legs will need to be lengthened to account for the extra contraction.
 - B. The flex legs will need to be shortened to account for the extra contraction.
 - C. The guides closest to the upwards facing 90 degree ells must be moved closer.
 - D. The flex legs are already able to deal with the expansion and contraction.
129. Steam piping for a Cast Iron Sectional steam boiler has been replaced with new A105 pipe. Before the boiler will run properly, which of the following procedures will be required?
- A. An operational boiler start-up is required.
 - B. A flue gas analysis is required.
 - C. A clean and flush is required.
 - D. Apply 150 psig test on boiler and system.
130. A float and thermostatic trap is backing up condensate. The start-up load is not extra heavy. There is no leakage in the coils of a steam to water heat exchanger connected to the system. What should you do?
- A. Check the thermostatic element.
 - B. Check the float orifice for blockage.
 - C. Check the float's air vent hole for blockage.
 - D. Check for dirt or wear on the seat and disc.

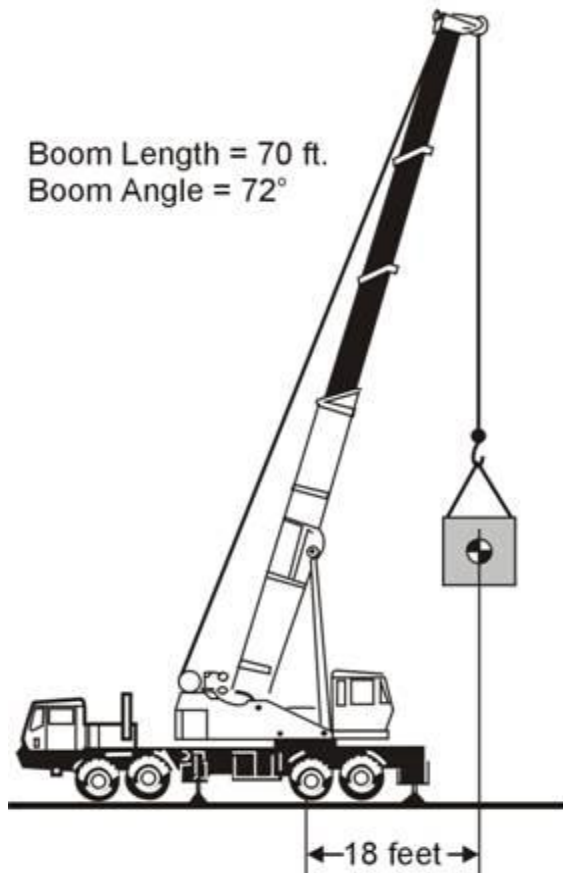

ON OUTRIGGERS FULLY EXTENDED OVER REAR								
Radius in Feet	Boom Length in Feet							84 ft 32ft Ext. **116
	*34	40	44	54	64	74	84	
10	100,000 (70)	74,000 (73)	72,000 (76)					
12	90,000 (66.5)	70,000 (70)	67,500 (73.5)	64,000 (76.5)				
15	72,000 (61)	63,700 (65.5)	61,000 (69)	55,000 (73)	44,700 (76)			
20	53,000 (50.5)	52,200 (57.5)	49,800 (62)	44,000 (67.5)	37,900 (71)	35,000 (74)	31,000 (78.5)	
25	41,000 (38.5)	41,000 (48)	41,000 (54)	36,300 (61.5)	31,900 (66)	29,200 (70)	27,500 (73.5)	17,500 (76.5)
30	29,690 (21.5)	29,690 (37.5)	29,690 (45)	29,690 (55.5)	27,000 (60.5)	25,000 (65.5)	23,900 (69.5)	18,600 (75)
35		22,650 (23)	22,650 (34.5)	22,650 (48.5)	22,650 (55)	21,800 (61)	20,500 (66)	14,500 (72.5)
40			18,090 (19)	18,090 (41)	18,090 (49)	18,090 (58.5)	17,900 (62)	12,800 (70)
45				14,840 (31.5)	14,840 (42)	14,840 (51.5)	14,840 (58)	11,400 (67)
50				12,330 (17.5)	12,330 (35)	12,330 (46)	12,330 (53.5)	10,200 (64.5)
55					10,440 (26)	10,440 (40.5)	10,440 (49)	9,190 (61.5)
60						9,100 (12.5)	9,100 (34)	8,440 (59)
65							7,990 (25.5)	7,760 (56)
70								7,100 (53)
75								6,630 (49.5)
80								6,130 (46)
85								5,360 (42.5)
90								4,630 (39)
95								3,980 (34.5)
100								3,420 (29.5)
105								2,940 (24)
110								2,560 (16)

Note: Boom angles are in degrees A5-829-002748 & 002760

Fig. 4

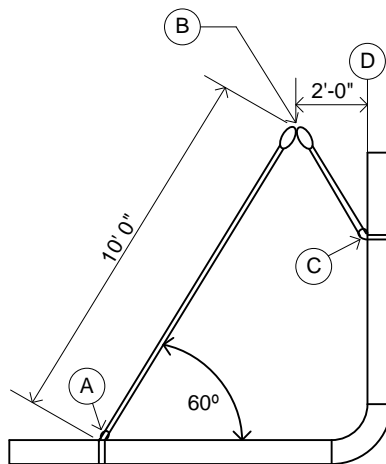

Figure 5

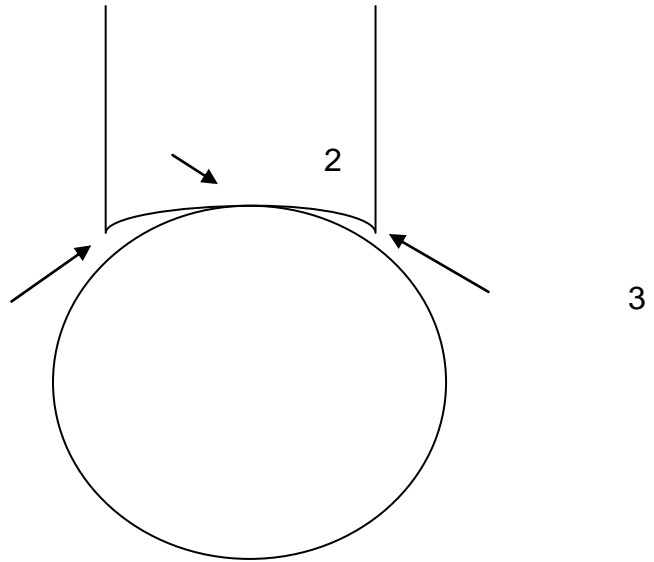

Figure 6

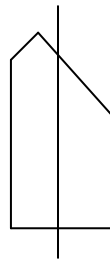

Figure 7